

**LABORATORY MANUAL**  
**ON**  
**AUTOMOBILE ENGINEERING LAB**  
*6TH SEMESTER*  
**DEPT. OF MECHANICAL ENGG.**



**SANJAY MEMORIAL INSTITUTE OF TECHNOLOGY**  
**DIPLOMA ENGG. WING, ANKUSHPUR**

**PREPARED BY**

**Er. KALI PRASASD PANIGRAHI**

**(H.O.D., MECHANICAL ENGG. DEPT)**

**Er. LINGARAJ MOHANTY**

**(ASST. PROF. MECHANICAL ENGG. DEPT)**

## **Pr.1 - AUTOMOBILE ENGINEERING LAB**

Name of the Course: Diploma in MECHANICAL ENGINEERING

Course code: Pr -1

Semester- 6th

Examination- 3 hrs

Practical periods: 4 P/W

Sessional- 50

End Semester Examination: 50

### **COURSE OBJECTIVES:**

At the end of the course the students will be able to:

### **LIST OF PRACTICALS**

1. Study of Automobile chassis.
2. Study the differential mechanism of the Tractor.
3. Study the hydraulic braking system of automobile.
4. Study the cut section model of carburetor solex type and maruti car type.
5. Study the fuel pump cut section model.
6. Study the actual cut section of gear box.
7. Study of actual car engine.

# Experiment No. - 1

## Study of automobile chassis

**Objective:** Students will be able to study different types of chassis used in vehicles and operations thereof.

### Theory:

In most passenger cars a pressed-steel frame—the vehicle's chassis—formed a skeleton on which the engine, wheels, axle assemblies, transmission, steering mechanism, brakes, and suspension members were mounted. The body was flexibly bolted to the chassis during a manufacturing process typically referred to as body-on-frame construction. This process is used today for heavy-duty vehicles, such as trucks, which benefit from having a strong central frame, subjected to the forces involved in such activities as carrying freight, including the absorption of the movements of the engine and axle that is allowed by the combination of body and frame.

In modern passenger-car designs, the chassis frame and the body are combined into a single structural element. In this arrangement, called unit-body (or uni-body) construction, the steel body shell is reinforced with braces that make it rigid enough to resist the forces that are applied to it. Separate frames or partial “stub” frames have been used for some cars to achieve better noiseisolation characteristics. The heavier-gauge steel present in modern component designs also tends to absorb energy during impacts and limit intrusion in accidents.

### Chassis Components :

- **Frame:** Made up of two long girders / members riveted or welded together with help of many cross-sections.
- **Engine:** Prime mover or energy generator of the vehicle.
- **Clutch:** Coupling incorporated between the engine and gearbox. Its function is to keep the prime mover moving even when it is not mobile.
- **Gear-box:** It has 4, 5 or 6 sets of gears to provide different torques and speed requirement
- **Propeller shaft:** Long hollow shaft to transmit power from gearbox to rear axle.
- **Rear axle:** Final unit in power transmission. Also called as a differential assembly. It helps to turn of the vehicle without skidding. It contains set of Bevel gears.
- **Suspension system:** Consists of leaf or coil spring. It connects the body to the chassis acting as shock absorbers for the body reducing vibrations.
- **Steering assembly:** Mechanism to steer the front wheels in order to turn and control the vehicle.
- **Brake system:** Controls the vehicle to stop or slow down in a periods of emergency.
- **Front axle:** it supports the front part of the vehicle. Some vehicles also contain differential in its front axle (4WD).
- **Electrical systems:** It is the lifeline of the vehicle as it connects various electrical connections and provides seamless transport capabilities.
- **Fluid systems:** arteries of a vehicle carrying fluids s.a. brake, clutch fluids and also fuel from tank to the engine.

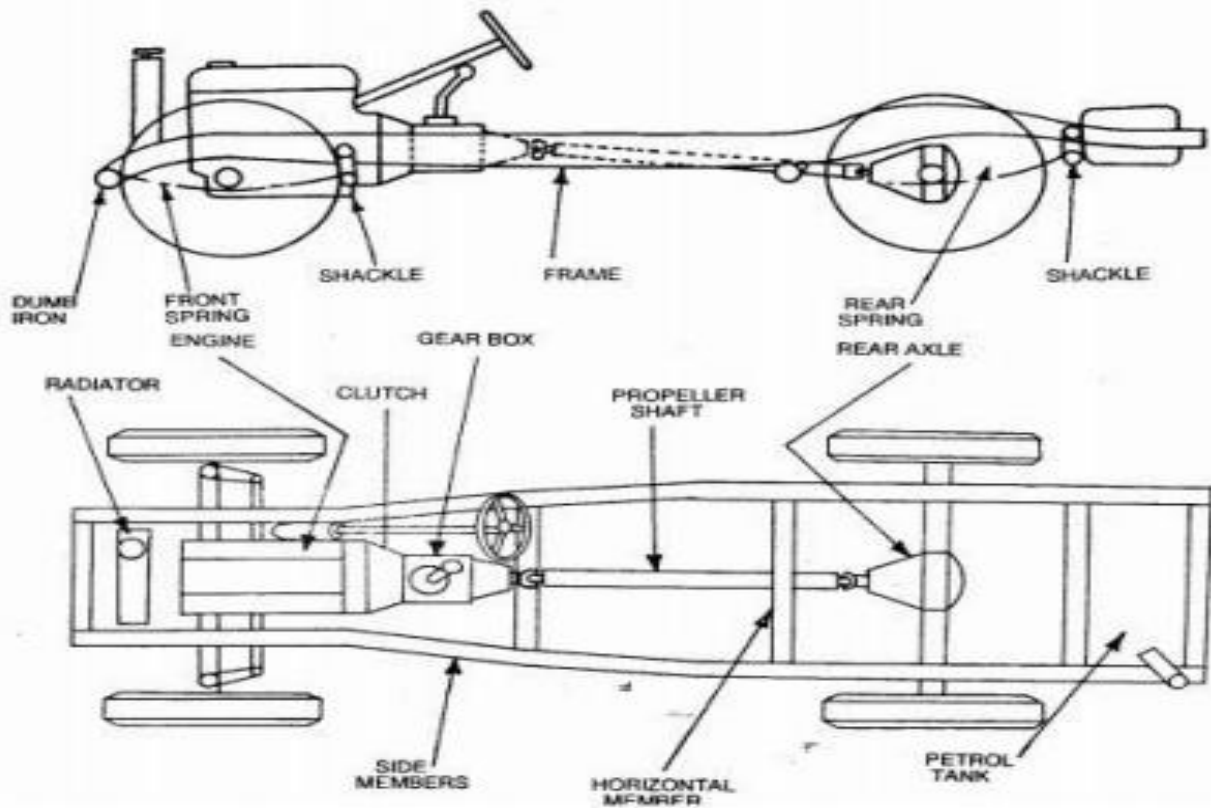

## BASIC CHASSIS

### Equipment's used:

Automobile chassis

### Observation:

### Assignment Questions –

1. Draw the layout of transmission system.
2. What is sub frame- Write their advantages?
3. List the requirements of clutch.
4. Mention the purpose of gear box and write their types.
5. What are the various resistance offered to the motion of the vehicles ?

## Experiment no 2

### Study of differential mechanism of the tractor

#### Objective:

Students will be able to study the working of the tractor differential and its various parts.

#### Theory:

#### Differential:

Differential unit is a special arrangement of gears to permit one of the rear wheels of the tractor to rotate slower or faster than the other. While turning the tractor on a curved path, the inner wheel has to travel lesser the tractor to move faster than the other at the turning point. The output shaft coming from the gear box provided with a bevel pinion at the end of the shaft (Fig. 6). The bevel pinion is in mesh with a large bevel wheel known as the crown wheel.

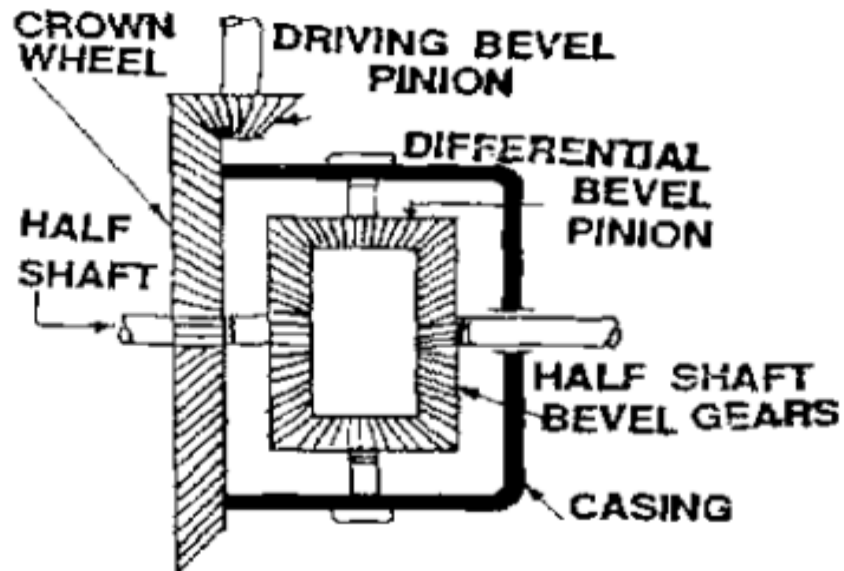

The main functions of crown wheel assembly are:

- (i) to transmit power through right angle drive to suit the tractor wheels.
- (ii) To reduce the speed of rotation.

The differential unit consists of:

- (i) differential casing
- (ii) differential pinion
- (iii) crown wheel
- (iv) Half shaft and
- (v) bevel gear.

Transmission gears Sliding-type gearbox for 4 speeds

The differential casing is rigidly attached with the crown wheel and moves like one unit. Two pinions are provided inside the differential casing, such that they are carried run around the crown wheel but they are free to rotate also on their own shaft or stud. There are two or more bevel gears in mesh with differential pinion. One bevel pinion is at the end of each half shaft, which goes to the tractor rear wheel. Thus instead of the crown wheel being keyed directly to a solid shaft between the tractor wheels, the drive is taken back from the indirect route through the differential casing, differential pinion, and half shaft of the tractor.

When the tractor is moving in a straight line, the differential pinion does not rotate on the stub shaft but is solid with the differential casing. They drive the two bevel gears at the same speed and in the same direction as the casing and the crown wheel. Each differential pinion can move in two planes simultaneously. When it is carried run around the casing, it drives the halfshaft in the same direction but when it is rotated on its own shaft, it drives them in the opposite direction i. e. rotation of differential pinion adds motion to one shaft and subtracts motion from the other shaft.

**Differential lock:** Differential lock is a device to join both half axles of the tractor so that even if one wheel is under less resistance, the tractor comes out from the mud, etc as both wheels move with the same speed and apply equal traction.

**Final drive:** Final drive is a gear reduction unit in the power trains between the differential and the drive wheels. The final drive transmits the power finally to the rear axle and the wheels.

The tractor rear wheels are not directly attached to the half shafts but the drive is taken through a pair of spur gears. Each half shaft terminates in a small gear, which meshes with a large gear called bull gear. The bull gear is mounted on the shaft, carrying the tractor rear wheel. The device for final speed reduction, suitable for tractor rear wheels is known as the final drive mechanism.

**Equipment used:** Tractor differential cut-section.

**Precautions:**

1. Hands must not be put inside the cut section or the cut parts in order to avoid sharp edges.
2. Greasing / Oiling should be carried out at regular intervals.

**Observation:**

**Assignment Questions –**

1. What will happen if differential is not used in an automobile?
2. Why differential is needed in automobile how it works?
3. Which gear is called the heart of the differential?

# Experiment No - 3

## Study of hydraulic braking system of an automobile

### Objective:

Students will be able to understand the working of brakes using hydraulic arrangement.

### Theory:

The hydraulic braking system is a type of braking system in which, unlike the mechanical braking system, hydraulic fluid is used to transmit the brake pedal or brake lever force from the brake pedal or brake lever to the final drum shoes or disc caliper in order to achieve braking. In this type of braking system the mechanical force transmitted by the driver on the brake pedal is converted into hydraulic pressure by a device known as a master cylinder and then this hydraulic pressure is sent to the final drum or disc caliper in order to stop or de-accelerate the vehicle.

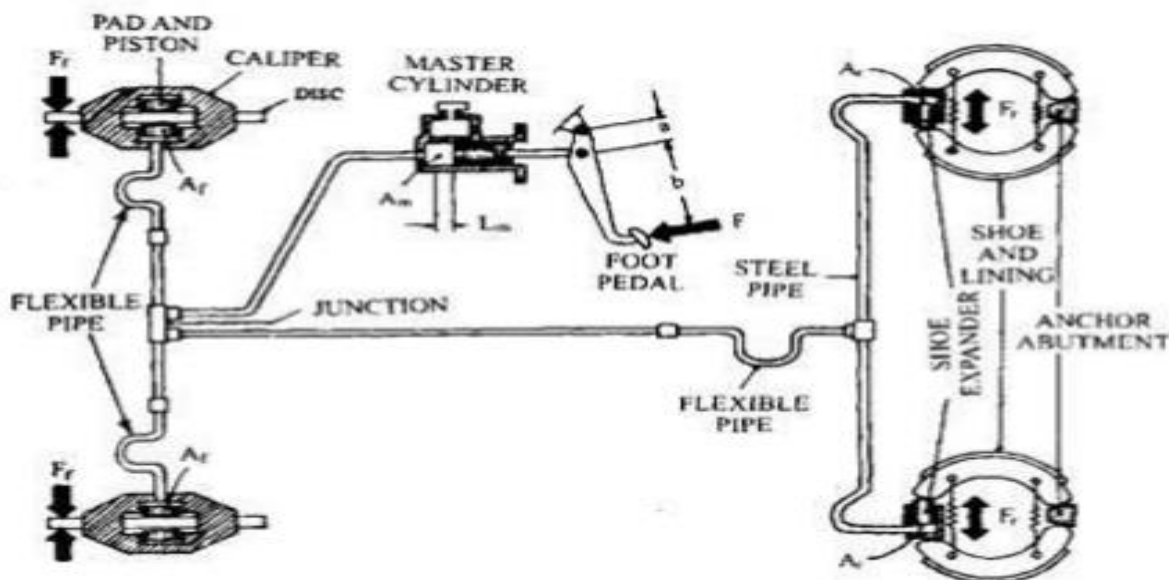

### Types :

Hydraulic braking system are classified on 2 basis-

1. On the basis of frictional contact mechanism-

On this basis, hydraulic brakes are of 2 types –

- (i) Drum brake or internal expanding hydraulic brakes.
- (ii) Disc brakes or external contracting hydraulic brakes.

2. On the basis of brake force distribution- on this basis, hydraulic brakes are of 2 types-

- (i) Single acting hydraulic brakes
- (ii) Dual acting hydraulic brakes

On the Basis of Frictional Contact Mechanism

### 1. Drum Hydraulic Brake or Internal Expanding Hydraulic Brakes

In drum hydraulic braking system the parts involved are-

- **Brake pedal or brake lever-** In hydraulic braking system same as other braking brake pedal or brake lever is required by the driver to apply braking, this brake pedal or brake lever is attached with the master cylinder through mechanical rod or connecting rod.
- **Master cylinder-** It is the simple cylinder and piston arrangement which converts the mechanical force from the brake pedal into the hydraulic pressure. The brake pedal is connected with the master cylinder's piston in such a fashion that the movement of pedal causes to and fro motion of the piston inside the master cylinder.
- **Brake fluid reservoir** – it is the simple reservoir tank containing brake fluid which is connected to the master cylinder with the help of brake hose.
- **Brake lines-** They are the hollow high pressure metal tube that connects the master cylinder with the drum cylinder inside these brake lines high pressure brake fluid from the master cylinder flows which is responsible for further brake actuation.
- **Drum cylinder-** It is the another cylinder fitted inside the drum of the drum brakes and is connected with the brake shoes , the high pressure brake fluid from the brake lines comes to this cylinder.
- **Brake drum** (refer to article on drum brake) – It is housing of drum cylinder , brake shoes and spring , the outer part of the drum rotates with the wheel and inner part consisting the brake shoe and cylinder remains stationary.

### 2. Disc Hydraulic Brakes or External Contracting Hydraulic Brakes

Disc hydraulic parts and drum hydraulic brake parts are almost same that are

- **Brake pedal or brake lever-** Exactly same as drum brakes mentioned above.
- **Master cylinder-** Same as drum brakes
- **Brake fluid reservoir-** Same as drum brake.
- **Brake lines** – Same as drum brake but here they connect the master cylinder with the disc calliper cylinder.
- **Disc rotor-** It is the metallic disc fitted with the wheel hub in such a fashion that it rotates with the wheel of a vehicle moreover disc rotor is the surface that make frictional contact with the brake shoe in order to stop or de accelerate the vehicle.
- **Disc caliper-** It is a small stationary component fitted over a disc just like a clamp, inside which there is a housing of brake shoes and hydraulic cylinder, when the brakes are applied the brake shoes inside the caliper contracts and make frictional contact with the rotating disc in order to provide braking.

### On the Basis of Brake Force Distribution

All the components of single acting hydraulic brakes and double-acting hydraulic brakes whether it's a drum type single acting brake or disc type single acting brake are same as mentioned above, the only difference is type of master cylinder used which decides the brake force distribution i.e. In bikes- single wheel braking or double wheel braking, In cars- two wheel braking or all wheel braking. So let's just see that in detail.



## 1. Single Acting Hydraulic Brakes

In single acting type of hydraulic brakes, simple single cylinder type of master cylinder is used which provides limited hydraulic pressure which can only be transferred in single direction i.e. In bikes- only single wheel, In cars – only single pair(front or rear) of wheels.

## 2. Double Acting Hydraulic Brakes

In double acting type of hydraulic brakes, double or tandem master cylinder is used which provides higher brake force which can be transferred in double direction i.e. both wheels in bikes and all the wheels in cars.

### Working of a Hydraulic Braking System :

#### 1. Drum Hydraulic Brake

When the driver apply brakes in a vehicle equipped with drum type hydraulic brakes following process take place-

- Due to the movement or actuation of brake pedal the connecting rod attached in between pedal and piston of a master cylinder moves which in turn pushes the master cylinder's piston inside the master cylinder just like a medical syringe.
- Due to this movement of the piston inside the master cylinder the compression of brake fluid inside the master cylinder takes place which in turn provides the conversion of mechanical energy into hydraulic pressure.
- This highly compressed brake fluid from the master cylinder moves inside the brake and the transfer of this hydraulic pressure from the master cylinder to the brake drum takes place.
- When this high pressure brake fluid enters the wheel cylinder or drum cylinder due o its high pressure , movement in the cylinder piston takes place which in turn expands the stationary brake shoes attached to it.
- Due to the expansion of the brake shoes, frictional contact between brake shoes and drum lining (the rotating drum part) is made which in turn converts the kinetic energy of the vehicle into heat energy and finally, braking occurs.

**Single Acting Drum Type Braking** –The working of the single-acting drum type hydraulic brake is exactly the same as mentioned above, in this type of braking single wheel or a single pair of wheels gets the braking force.

**Double Acting Drum Type Braking-** In double acting hydraulic brake the high pressure brake fluid from the master cylinder is distributed in 2 directions i.e. both the wheels in bikes and all wheels in cars due to the use of tandem master cylinder ( refer to the article on master cylinder)

#### 2. Disc Hydraulic Brakes

When the driver applies brake in a vehicle equipped with disc type hydraulic brakes the process involved is same as drum hydraulic bakes up to when the high pressure brake fluid enters the brake lines but differ a bit after that –

- The high pressure brake fluid from the brake lines enters the disc calliper cylinder of a disc brake system.
- This high pressure brake fluid cause's movement in the calliper cylinder's piston which in turn causes the movement of the brake pad attached to the piston inside the calliper.
- Due to this movement of brake pad the clamping of the rotating disc rotor takes place and due to this frictional contact between brake pads and the rotating disc rotor, conversion of vehicle's kinetic energy into heat energy takes place which in turn stops or de accelerate the vehicle

**Single Acting Disc Type Braking-** The working of single acting disc type hydraulic braking is exactly same as mentioned above, in this type of braking single wheel or a single pair of wheels gets the braking force.

**Double Acting Disc Type Braking-** In double acting disc type hydraulic brake the high pressure brake fluid from the master cylinder is distributed in 2 directions, i.e. both the wheels in bikes and all wheels in cars due to the use of tandem master cylinder ( refer to the article on master cylinder).

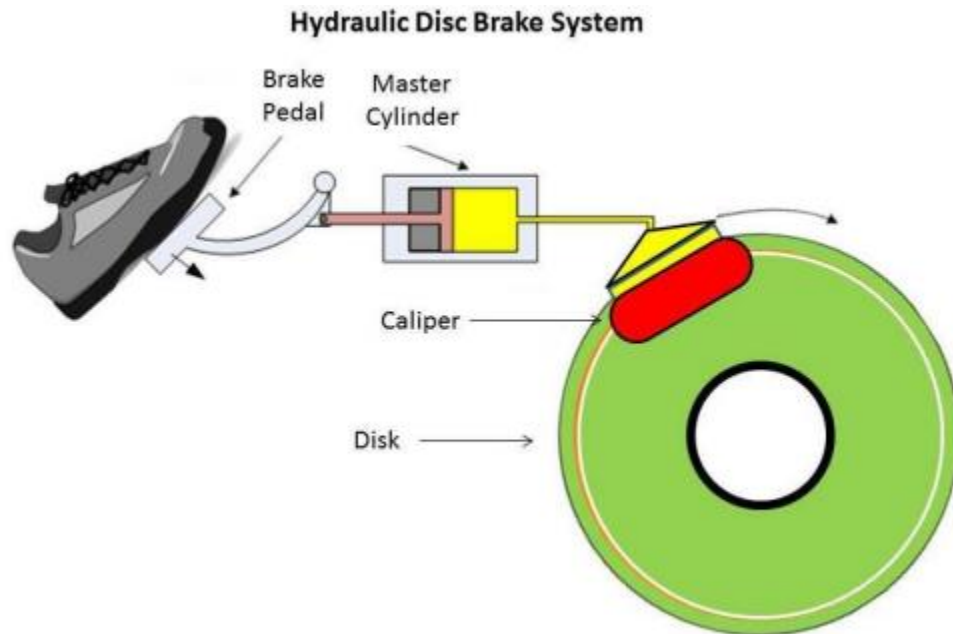

**Equipment used:**

Working model of Hydraulic braking arrangement.

**Observation:**

**Assignment Questions –**

1. What is the most common problem in a brake hydraulic system?
2. Why water is not used in hydraulic brakes?
3. Which principle is applicable for hydraulic brakes?
4. Why must air be excluded from the hydraulic system?
5. How do you check hydraulic brakes?

## Experiment No - 4

### Study the cut section model of carburetor solex type and Maruti car type

#### Objective:

Students will be able to understand the functioning of the inner parts of a carburetor and working thereof.

#### Theory:

Solex Carburetor is a downdraught Carburetor. This is used mostly in the automobile engines. As we already discussed the main drawback of the simple Carburetor is the maintaining one air-fuel ratio at one throttle position. This Solex Carburetor can provide the rich mixture when the engine needs to start and supply the lean mixture when the cruising (Travelling with smoothly with economical speed) the vehicle.

This Carburetor has different fuel discharge circuits so that it can deliver different mixtures for the different operating conditions such as the Engine Starting, Engine Idling, Low-speed Operation, Normal Operating, and Acceleration.

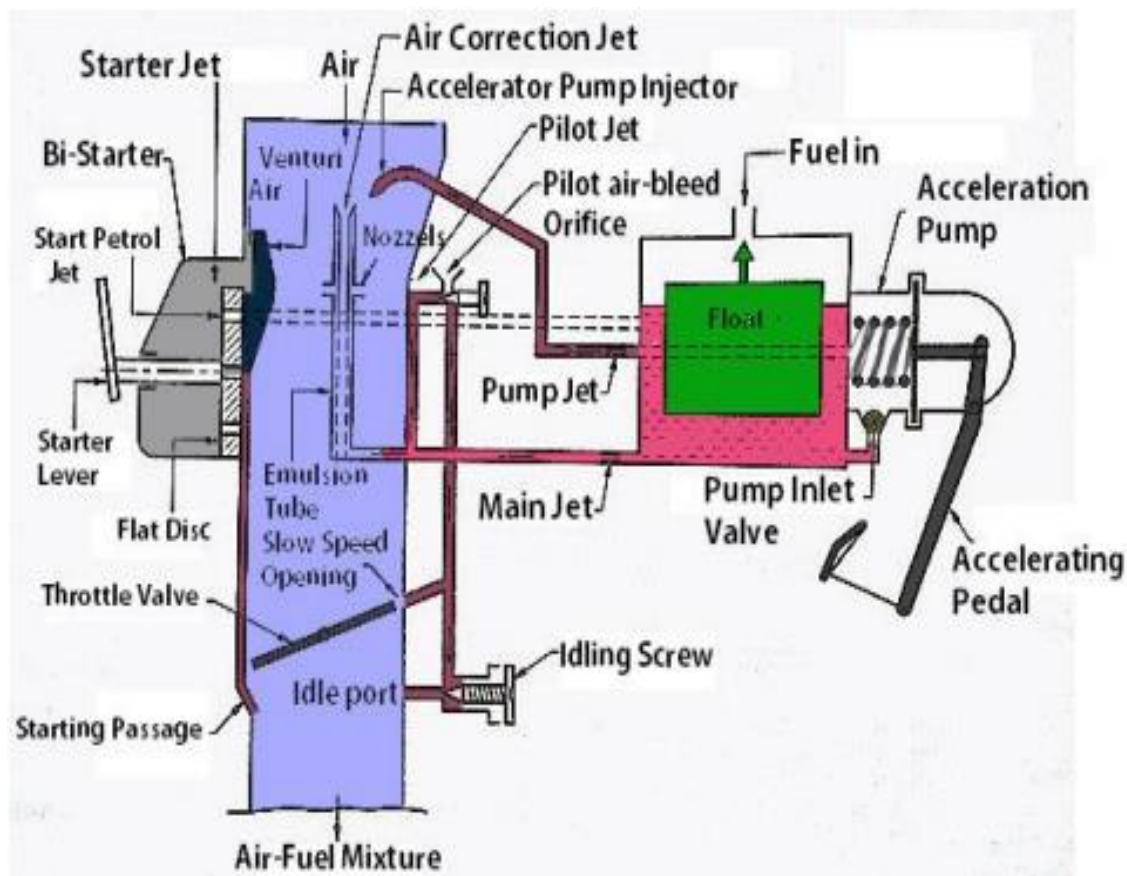

A float with a tapered valve at the top face of the float is arranged in the float chamber to take care of the fuel level in it as shown in the below schematic representation.

#### Solex Carburetor

- The Main metering Jet will discharge the fuel into the venturi throat tube.
- The fuel from the main metering jet will go into the air-bleed emulsion system, this has the lateral holes as shown in the schematic diagram.

- Air correction jet calibrates the air entering through it and ensures the air-fuel balance.
- The metered emulsion of fuel and air is supplied through the spraying orifice or nozzles. These nozzles are drilled horizontally on the vertical pipe in the choke tube as shown in the schematic diagram.
- There is a throttle valve provided at the end of the tube to control the air-fuel mixture quantity supply into the engine. This valve also known as the conventional butterfly valve.

With this circuit, the engine can run at the normal running with this Solex Carburetor. But for the other operating conditions of the engine, we will use different fuel circuits for different operating conditions.

### **Cold starting and warming**

The main advantage with the Solex Carburetor is that it has the Bi-Starter also known as the progressive starter. Initially, the engine needs a richer mixture and the after starting of the engine, the mixture supposed to be lean. So this progressive starter will do the job for the engine.

- This starter is in the form of a flat disc with the holes of different sizes.
- The starter petrol jet and the starter jet (Air) are connected together by the holes present in the starter disc and open into the passage arranged to below the throttle valve.
- There is a starter lever that used to adjust the hole sizes so that the amount of the fuel and the air will be passed to the engine cylinder in the suction stroke.
- When we starting the engine we will close the throttle and provide the air-fuel mixture from the starting passage which is having a richer mixture from this Bi-Starter setup.

Once the engine started, we have to warm it up by accelerating a couple of times and then release the throttle valve and pass the lean/normal mixture thru the venturi throat.

### **Idling and Slow Running of the Engine (Cruising)**

Idling of the engine is at where the engine will not deliver any work it only delivers enough power for its auxiliaries. During this idling or slow running of the engine needs to have a rich mixture and because of the cylinder pressure is less and then there is a chance of re sucking of the exhaust gases and cause the poor combustion to make the engine stumble. So this rich mixture helps in making it happen smooth.

- During the Idling, the throttle valve is closed completely.
- The suction created by the suction stroke is acted on the pilot jet directly.
- The fuel will be inducted from the pilot jet and mixed with the less amount of air sucked from the pilot air-bleed orifice from the outside atmosphere.
- This rich mixture will be directly sent to the cylinder by a tube directly opened right below the throttle valve as shown in the schematic diagram.
- There is an idle speed adjustment screw is arranged so that we can set the idle speed of the engine by controlling the amount of mixture injected.
- For the smooth running adjustment, we will have an additional by-pass adjustment. (Not shown in the schematic representation) Which will make the less rich mixture and the throttle will also open a little bit. so that engine can run smoothly with the full movement of the air-fuel mixture.

## **Acceleration of Engine**

For the Engine acceleration, and additional acceleration pump injector equipment is arranged right side of the floating chamber as you can see from the schematic diagram. This acceleration pump will supply the additional fuel for the engine with the help of the Acceleration pump injector directly on top of the venturi. The operating of the Carburetor is the same as the normal running but with the additional fuel drops the engine get excited when we press the accelerator pedal. When you release the pedal the accelerator pump will suck the fuel from the float chamber and stores for the next pedal movement.

### **Equipment's used:**

cut section model of solex and maruti type carburetor.

### **Precautions:**

1. Hands must not be put inside the cut section or the cut parts in order to avoid sharp edges.
2. Greasing / Oiling should be carried out at regular intervals.

### **Observation:**

### **Assignment Questions –**

1. Which type of carburetor The Solex is?
2. Where are Solex carbs made?
3. How do we identify a Solex carburetor?
4. What is the working Solex carburetor?

# Experiment No - 5

## Study the fuel pump cut section model

**Objective:** Students will be able to understand the inner functioning of a fuel pump.

**Theory:**

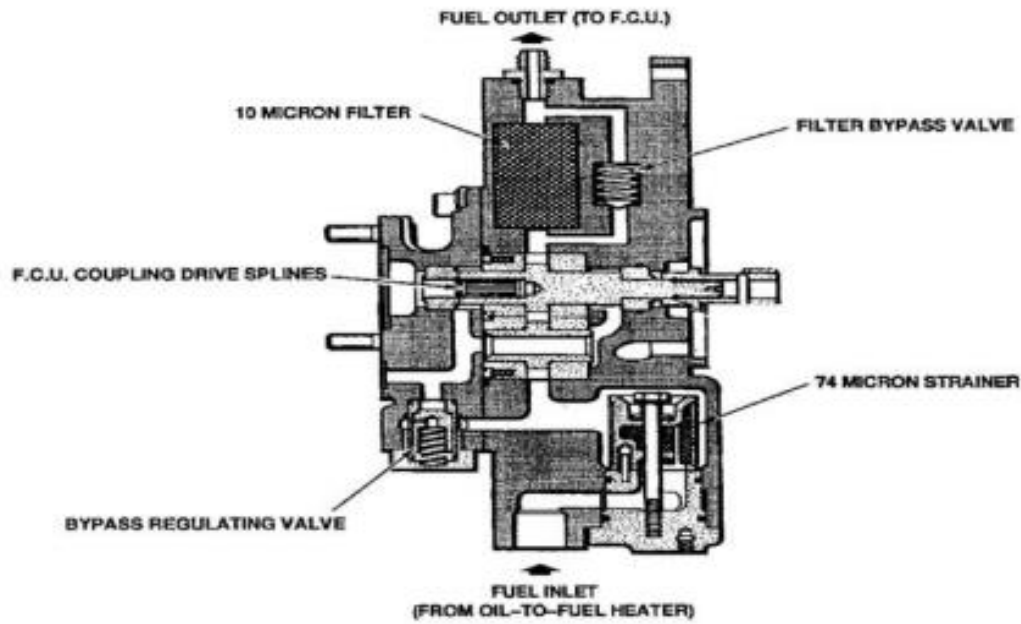

A car engine burns a mixture of petrol and air. Petrol is pumped along a pipe from the tank and mixed with air in the carburetor, from which the engine sucks in the mixture. In the fuel-injection system, used on some engines, the petrol and air are mixed in the inlet manifold. A fuel pump draws petrol out of the tank through a pipe to the carburetor. The pump may be mechanical worked by the engine - or it may be electric, in which case it is usually next to or even inside the fuel tank.

The purpose of the fuel pump is to meter the correct quantity of fuel and deliver it at the correct time to the engine cylinder according to the varying load and speed requirements.

### Construction and Working of Mechanical Fuel Pump

Mechanical fuel pump is function also directly or during a push rod, through an eccentric on Camshaft.

It consists of following major parts:

- (1) Rocker arm, return spring and connecting link
- (2) Sediment bowl with retainer.
- (3) Lower body contains diaphragm, link and spring.
- (4) Upper body contain inlet and outlet check valves.

While camshaft turns, rocker arm of fuel pump is motivated back and forth. The unusual on camshaft pushes the rocker arm laterate towards body of fuel pump. As the eccentric move off, go back spring pushes rocker arm forward towards engine camshaft. As the rocker arm is pressed back through the eccentric diaphragm in pun is pulled down, which

make in the major chamber. During this point, Inlet valve opens due to suction cause and fuel rush into the major chamber as of the inlet chamber. When eccentric pressure on rocker arm is out, the diaphragm moves upwards due to tension of the spring placed under it. At this time the outlet valve opens with the fuel is pump out of fuel pump.

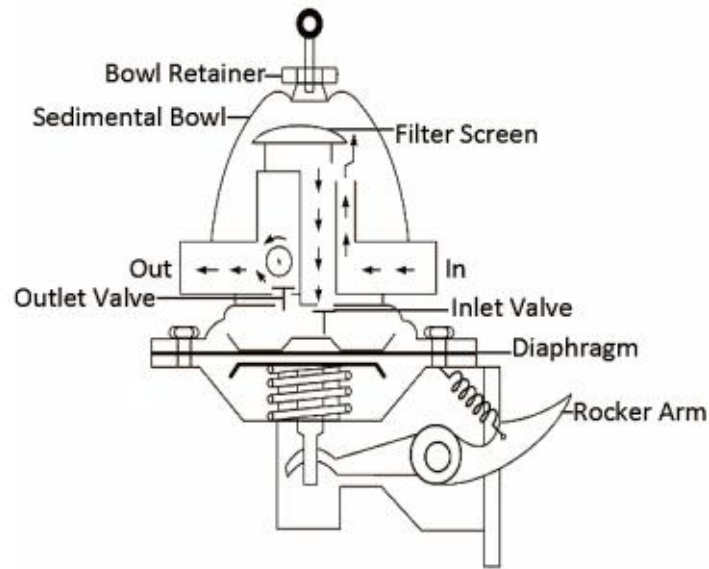

### Working of Mechanical Fuel Pump

As eccentric pushes rocker arm:

1. Diaphragm is pulled down during the connecting link.
2. Suction or vacuum is formed in the major chamber.
3. Inlet valve opens.
4. Fuel rushes into the major chamber.
5. Outlet valve remains closed.

Due to the up and down movement of diaphragm suction and pumping cause is repeat again and again. Fuel as of the tank is drawn and pumped to carburetor with this action of pump.

**Equipment used:** fuel pump cut section model.

### Precautions:

1. Hands must not be put inside the cut section or the cut parts in order to avoid sharp edges.
2. Greasing / Oiling should be carried out at regular intervals.

### Observation:

### Assignment Questions –

1. What affects the fuel pump?
2. What controls the fuel pump in a car?
3. How many types of fuel pumps are there?
4. What activates a fuel pump?

# Experiment No - 6

## Study the actual cut section of gear box

**Objective:** Students will be able to study the internal structure and operations of gear box.

**Theory:**

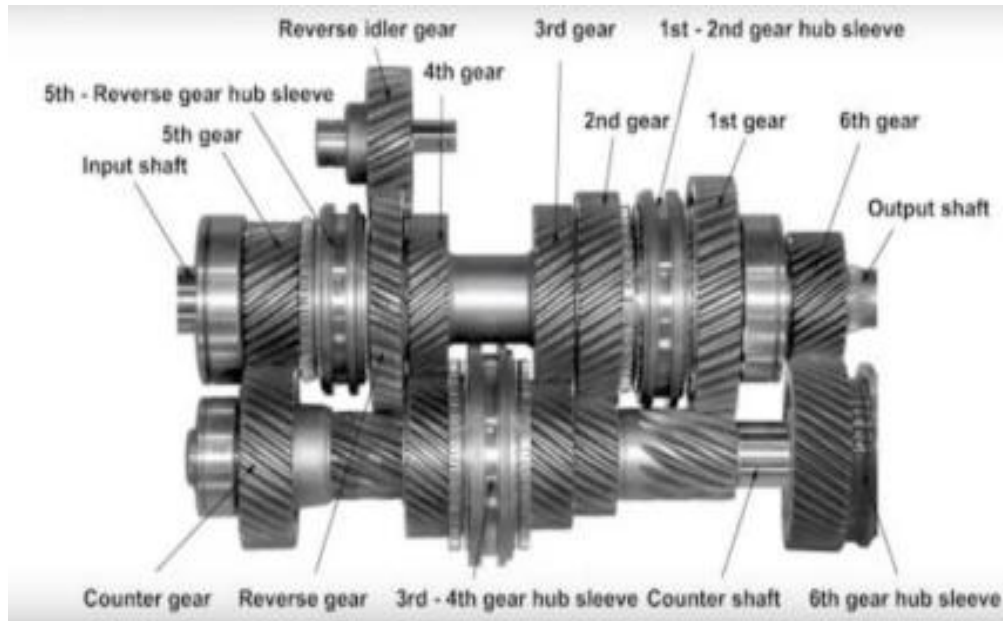

Gearbox is a contained gear train, or a mechanical unit or component consisting of a series of integrated gears within a housing. The gears inside of a gearbox can be any one of a number of types from bevel gears and spiral bevel gears to worm gears and others such as planetary gears. The gears are mounted on shafts, which are supported by and rotate via rolling element bearings. The gearbox is a mechanical method of transferring energy from one device to another and is used to increase torque while reducing speed. Gearboxes are used in many applications including machine tools, industrial equipment, conveyors, and really any rotary motion power transmission application that requires changes to torque and speed requirements. a gearbox is always a fully integrated mechanical component consisting of a series of mating gears contained in a housing with shafts and bearings (to support and resolve loads) and in many cases a flange for motor mounting.

### Parts of a Gearbox :

- 1. Main Shaft** - It is the shaft used as an output shaft in a gearbox, this shaft is usually kept parallel to the layshaft and in front of the clutch shaft or engine output shaft, the change of gear usually occur through this shaft as it is usually connected to the gear lever.
- 2. Clutch Shaft** - It is the shaft which carries the engine output to the gearbox, the engaging and disengaging of the engine output occurs with the help of clutch.
- 3. Layshaft or Counter Shaft** - It is the shaft through which the output of the engine is transferred to the main shaft by the continuous meshing of gear on the layshaft to the gear on the clutch shaft.
- 4. Gears** - They are the connecting circles with teeth that rotate and meshes with another gear on the different shaft in order to transmit the circular motion between 2 different shafts, they can be – spur gear, helical gear, bevel gear and worm gear.



**5. Synchromesh Devices** - They are the special devices used in modern gearbox (synchromesh gearbox) that makes the shifting of gears smooth by bringing the speed of main-shaft, lay-shaft and clutch-shaft at the same, they doesn't have to slide over the shaft for the shifting of the gear.

**6. Dog Clutches** - They were used in old gearboxes like constant mesh gearbox, to avoid the sliding of gear over the shaft for meshing or shifting. As they slide over the shaft in order to shift a gear.

**7. Gear lever** - It is the lever operated by the driver to change or shift the gear, the movement of the lever is designed in a particular fashion.

#### (i) Sliding Mesh Gearbox

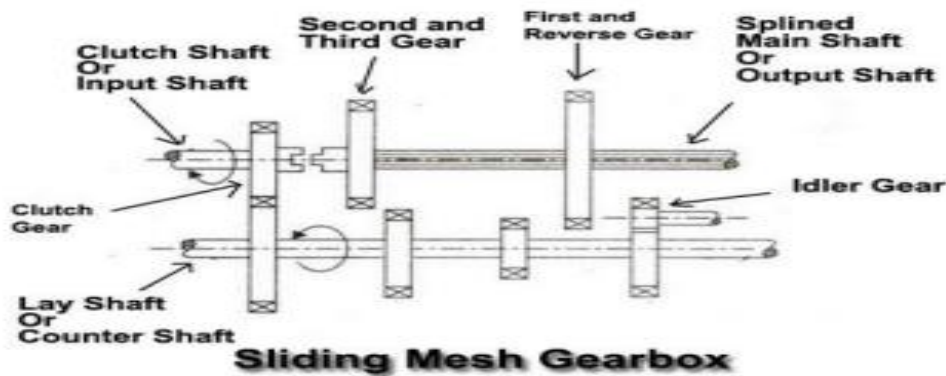

It is the oldest types of gearbox used, in sliding mesh gearbox the gears of main shaft and layshaft are not in mesh i.e. independent, only a single gear is in continuous mesh with the gear on the clutch shaft that rotates the lay-shaft and the meshing of gears with the appropriate gear on the lay-shaft occurs due to the left or right siding of the gears of the main shaft.

**Equipment used:** cut section of a gearbox.

#### **Precautions:**

1. Hands must not be put inside the cut section or the cut parts in order to avoid sharp edges.
2. Greasing / Oiling should be carried out at regular intervals.

#### **Observation:**

#### **Assignment Questions –**

1. What affects the gear box?
2. Which of the following is need of gear box?
3. How is gear box damaged?
4. In which of the gearbox all gear are always in contact?
5. Which gear train is used in automobile?
6. How many types of gear box are there?

# Experiment No- 7

## Study of actual car engine

### Objective:

Students will be able to understand the working of the engine components and fittings.

### Theory:

The term engine typically describes devices, like steam engines and internal combustion engines, that burn or otherwise consume fuel to perform mechanical work by exerting a torque or linear force (usually in the form of thrust). Devices converting heat energy into motion are commonly referred to simply as engines. Examples of engines which exert a torque include the familiar automobile gasoline and diesel engines.

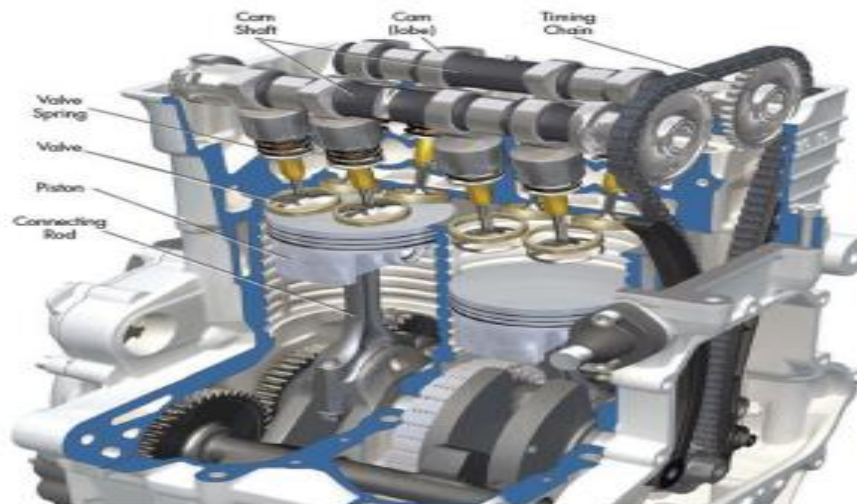

### Engine block

The block is the main part of the engine. All other parts of the motor are essentially bolted to it. Inside the block is where the magic happens, such as combustion.

### Pistons

Pistons pump up and down as the spark plugs fire and the pistons compress the air/fuel mix. This reciprocating energy is converted to rotary motion and transferred to the tires by the transmission, via the driveshaft, to make them spin.

### Cylinder head

The cylinder head is attached to the top of the block in order to seal the area to prevent the loss of gases. The spark plugs, valves and other parts are fitted to it.

### Camshaft

The camshaft opens and closes the valves in perfect timing with the rest of the parts.

### Crankshaft

Located near the bottom of the engine block, this is the part that converts energy from reciprocating to rotary.

## Valves

The valves regulate the flow of air, fuel and exhaust fumes inside the cylinder head. There are both intake valves and exhaust valves.

## Oil pan

The oil pan, also known as the oil sump, is attached to the bottom of the engine and stores all the oil used in the lubrication of the engine.

## Timing Belt/Chain –

The camshaft and crankshafts are synchronized to ensure the precise timing in order for the engine to run properly. The belt is made of a heavy-duty rubber with cogs to grasp the pulleys from the camshaft and crankshaft. The chain, similar to your bicycle chain wraps around pulleys with teeth.

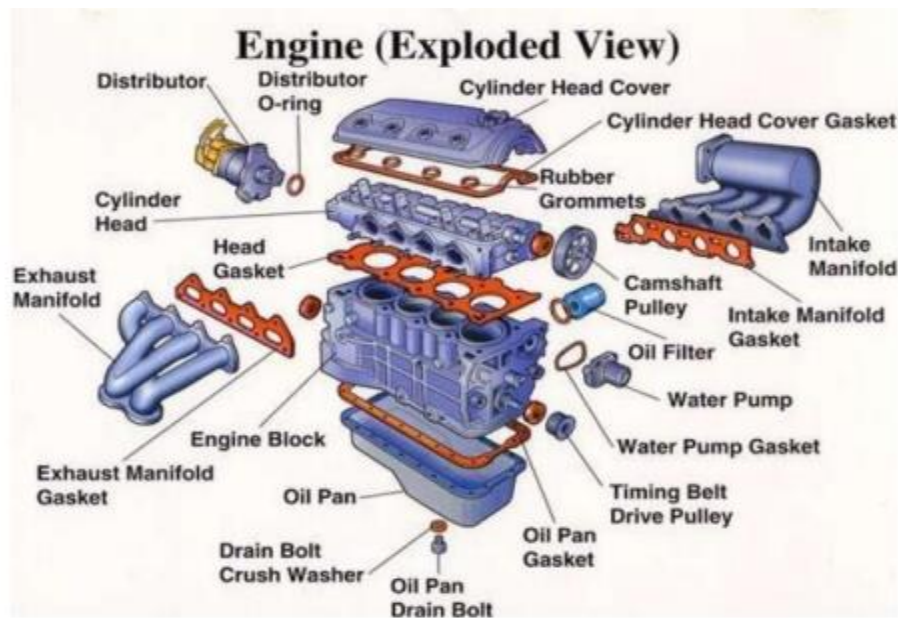

**Equipment used:** actual working engine.

## Precautions:

1. Hands must not be put inside the cut section or the cut parts in order to avoid sharp edges.
2. Greasing / Oiling should be carried out at regular intervals.

## Observation:

Assignment Questions –

1. What are the 3 types of engines?
2. What things use engines?
3. What do engines contain?
4. What do engines power?
5. Write down a about Is an engine a motor?